

VERSO BCU 350

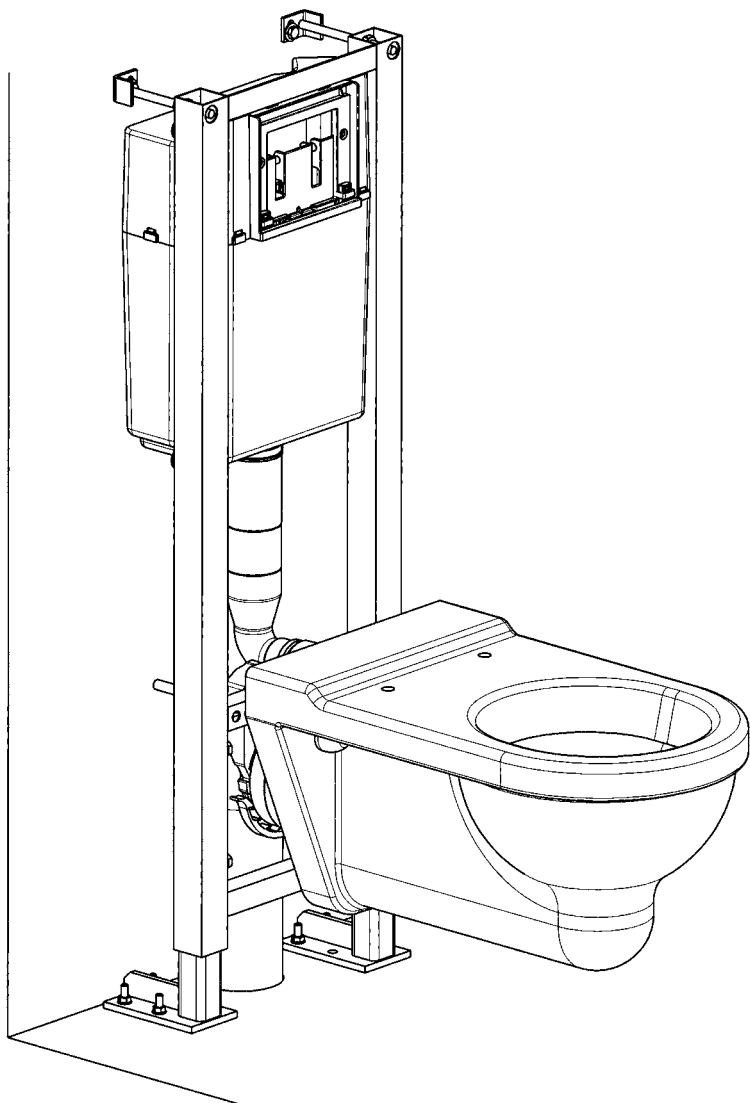

CZ: Návod pro montáž a údržbu

DAN: Brugsanvisning

DEU: Bedienungsanleitung

ESP: Manual de uso

FRA: Notice de montage et de maintenance

GB: Assembly and maintenance manual

GRE: ΟΔΗΓΙΕΣ ΓΙΑ ΤΗ ΣΥΝΑΡΜΟΛΟΓΗΣΗ ΚΑΙ ΤΗ ΣΥΝΤΗΡΗΣΗ

H: Kezelési és karbantartási útmutató

LT: Naudojimo instrukcija

NER: Gebruiksaanwijzing

NOR: Bruksanvisning



PL: Instrukcja montażu i konserwacji

ROM: Mod de folosire

RUS: ИНСТРУКЦИИ ПО УСТАНОВКЕ И ТЕХНИЧЕСКОМУ ОБСЛУЖИВАНИЮ

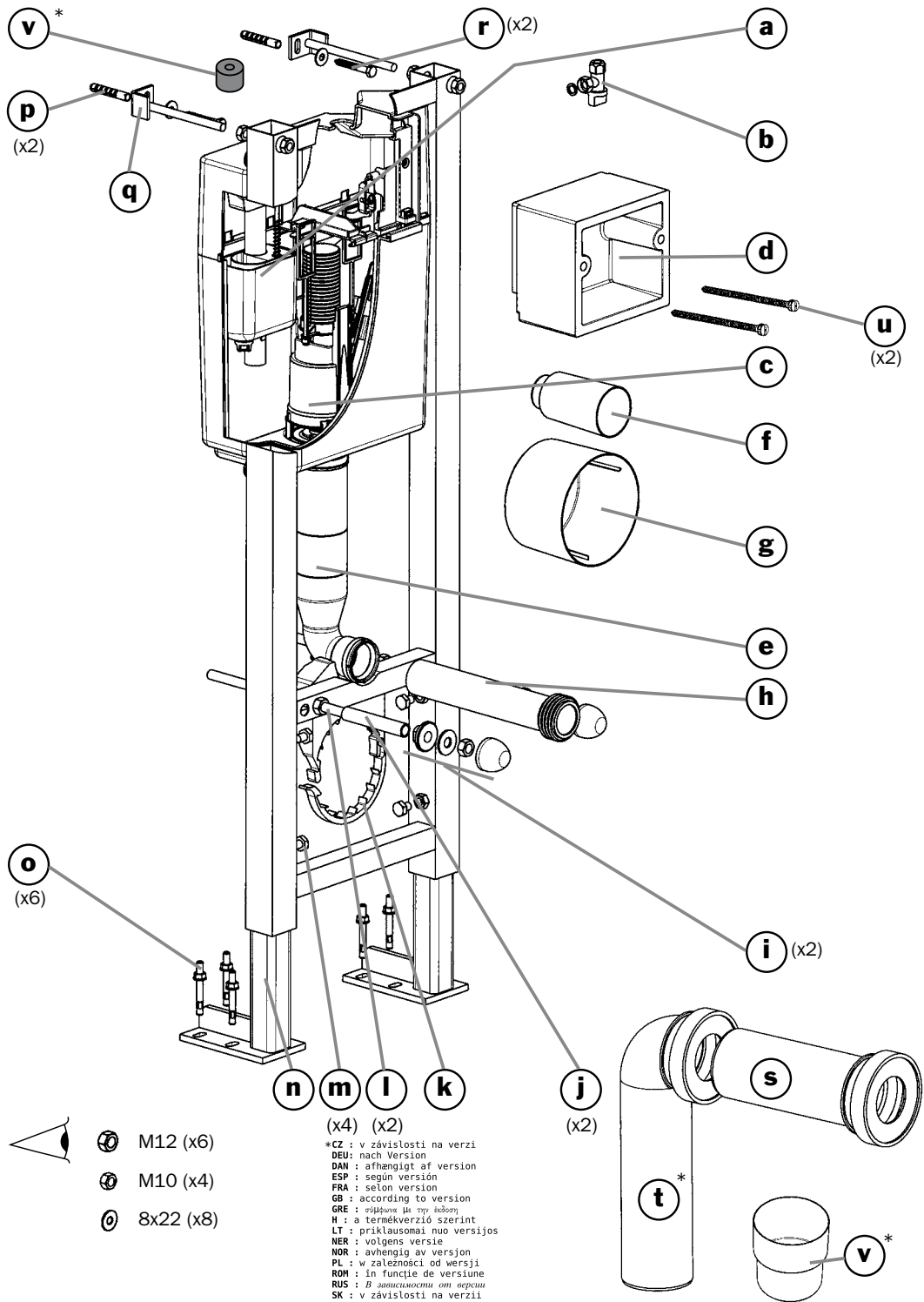
SK: Návod na montáž a údržbu



-  M12 (x6)
-  M10 (x4)
-  8x22 (x8)

- n** (x4)
- m** (x2)
- l**
- k**

*CZ : v závislosti na verzii
 DEU : nach Version
 DAN : afhængigt af version
 ESP : según versión
 FRA : selon version
 GB : according to version
 GRE : σύμφωνα με την έκδοση
 H : a termékverzió szerint
 LT : priklausomai nuo versijos
 NER : volgens versie
 NOR : avhengig av versjon
 PL : w zależności od wersji
 ROM : în funcție de versiune
 RUS : в зависимости от версии
 SK : v závislosti na verzii

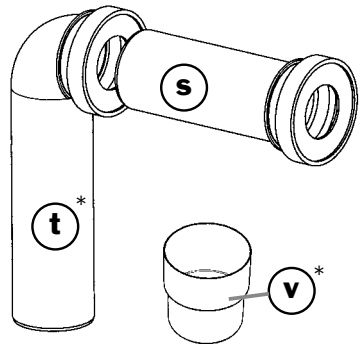

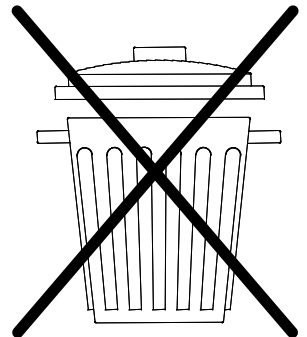
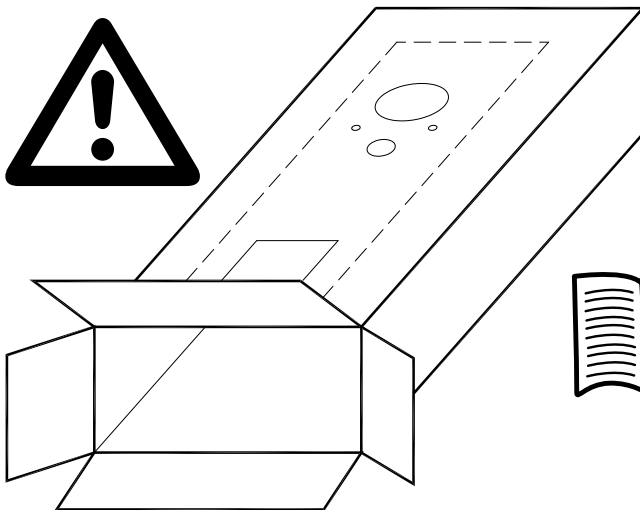
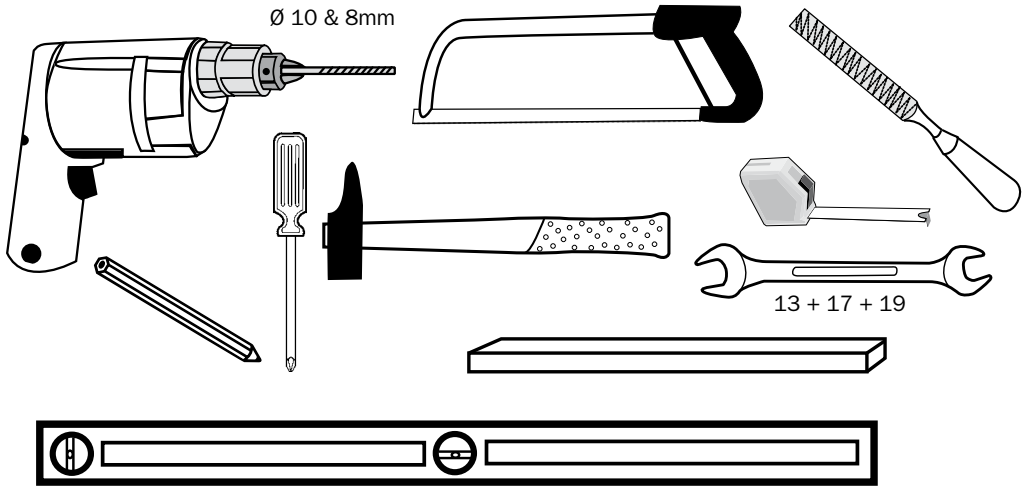
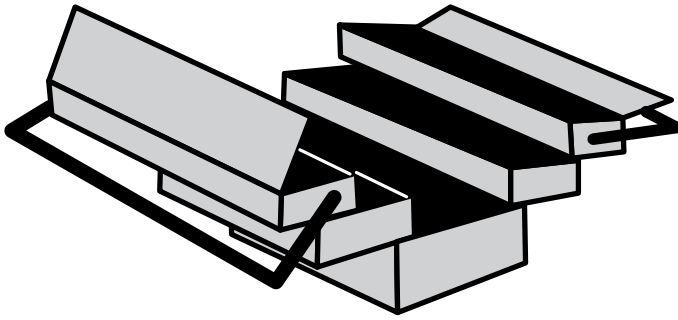

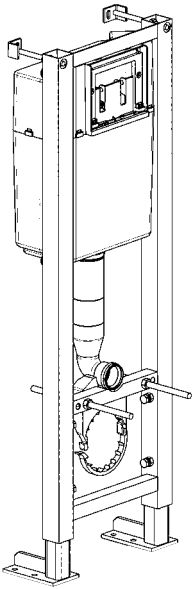
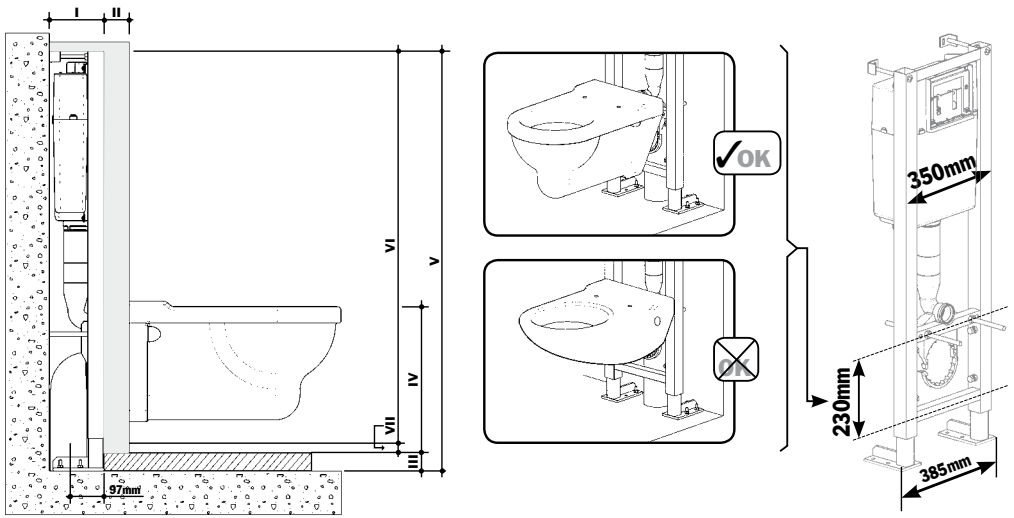

- I** = 147mm ↔ 245mm
- II** = 16mm ↔ 100mm
- III** = ≤ 185mm
- IV** = 400mm ↔ 480mm
- V** = 1100mm ↔ 1300mm

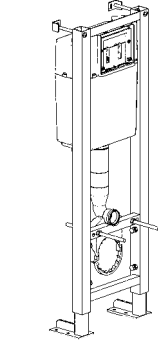

+ MEUBLEO

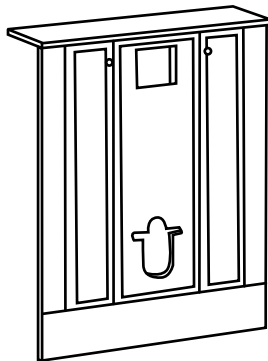

I = 210mm 245mm

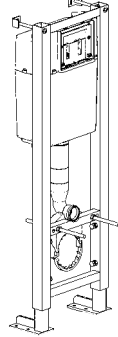

+ DECOFAST

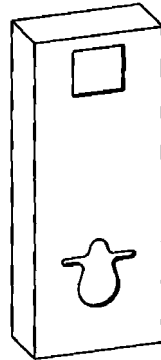

- I** = 204mm ▲
- VI** = 1104mm ▲
- VII** = 2mm ▲

1

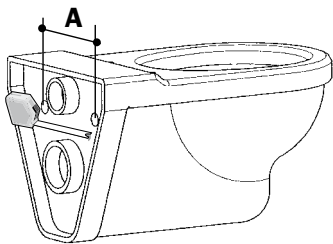

A = 180mm → **2-1**

A = 230mm → **2-2**

2-1

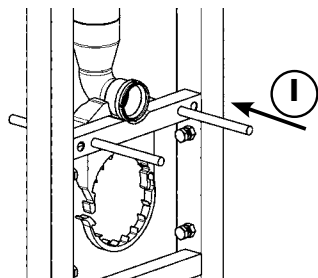

2-2

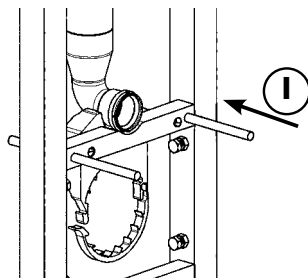

3

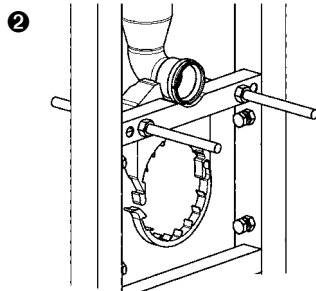
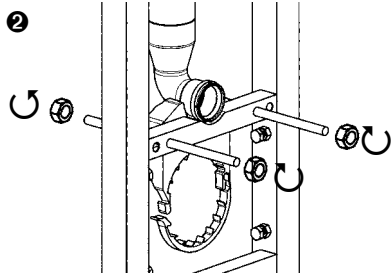

4

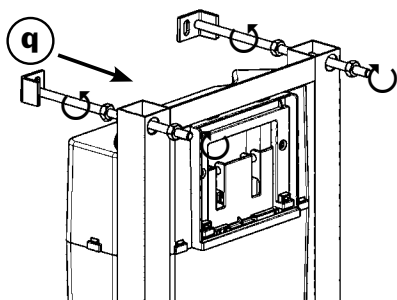

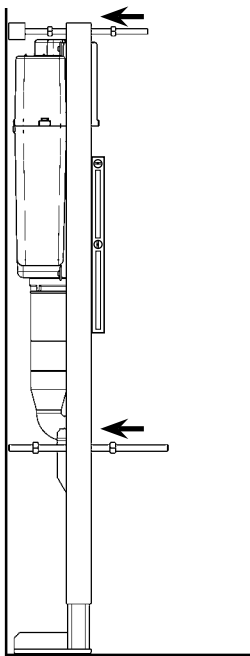
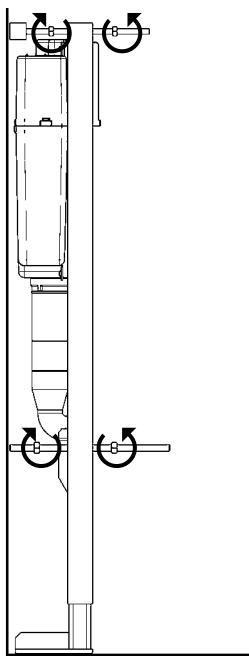
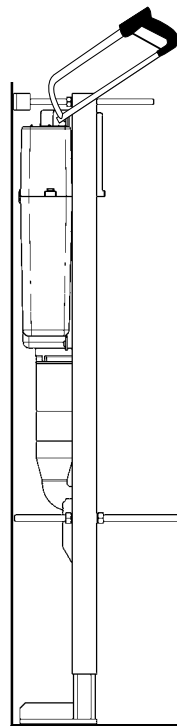
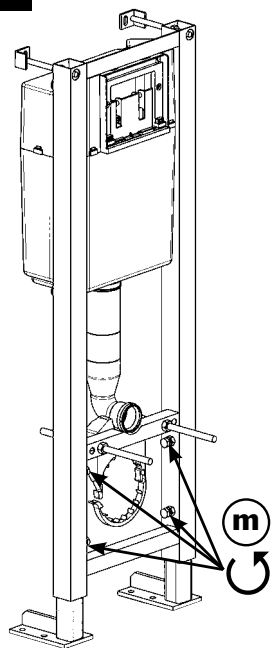
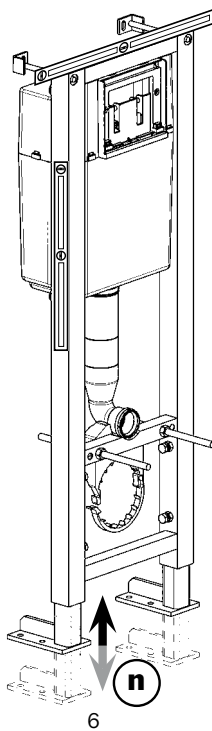
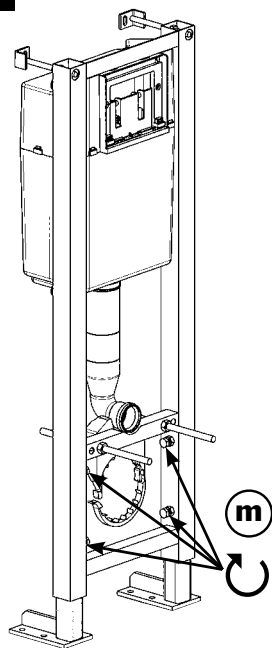
5**6****7****8****9****10**

11

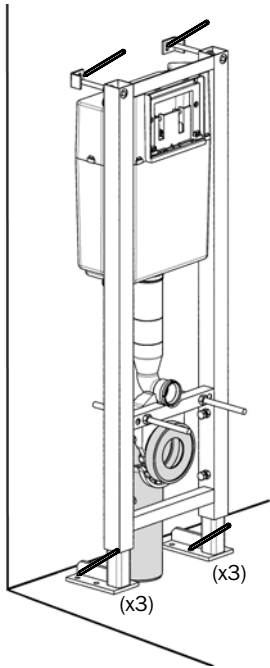

12

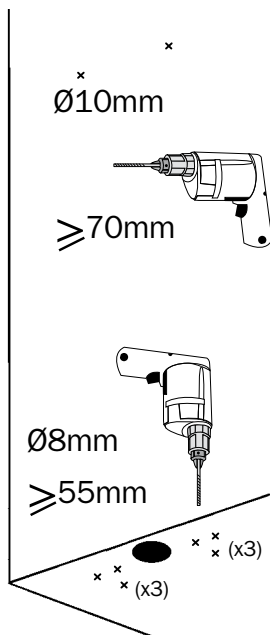

13



14

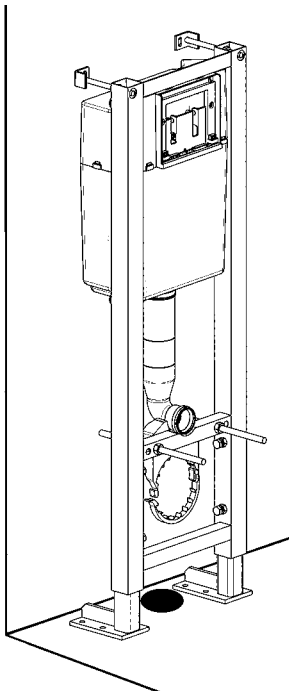

15

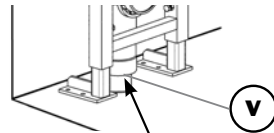
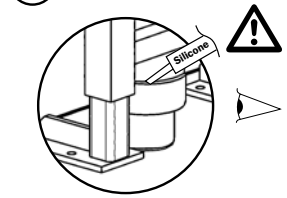
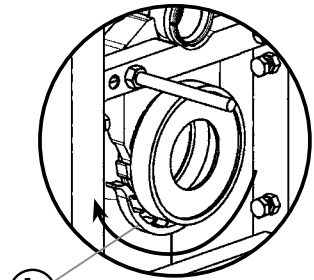
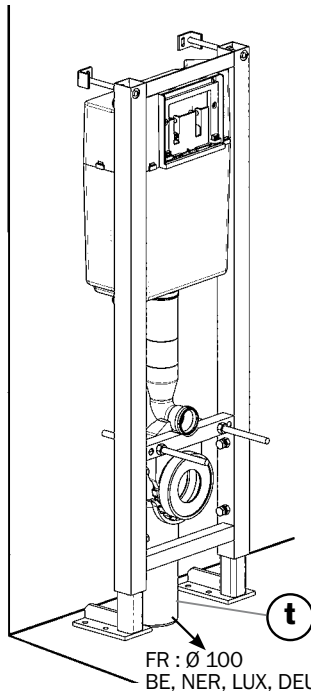

FR : Ø 100
 BE, NER, LUX, DEU, PL : Ø 110

BE, NER, LUX : Ø 90

16

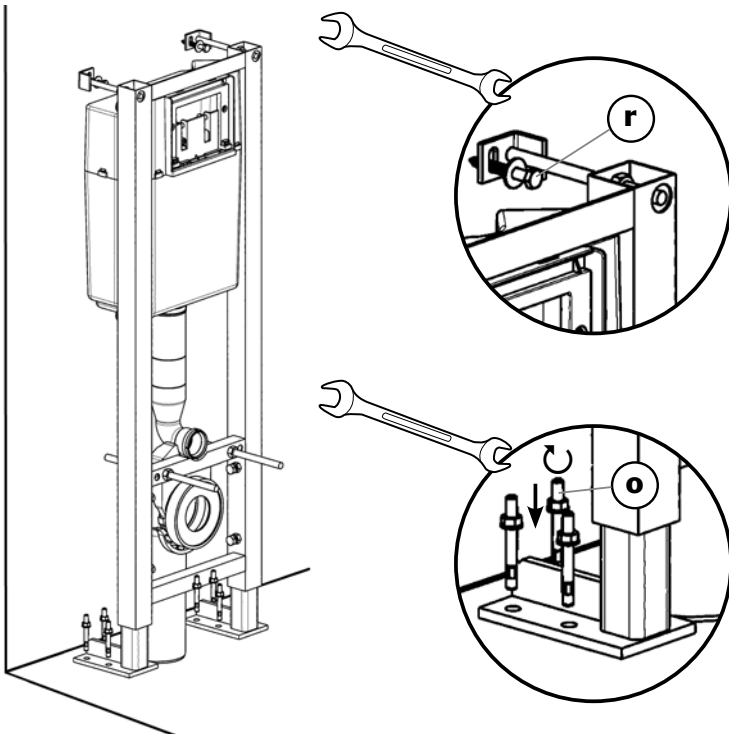

17

1

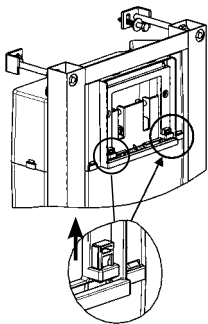

2

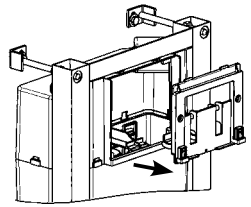

3

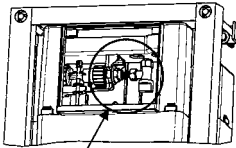

4

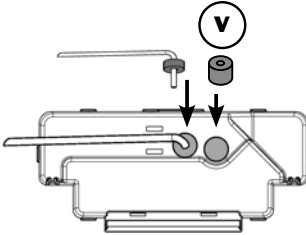

5

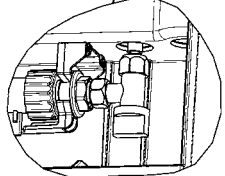
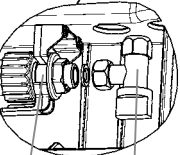
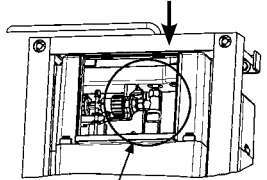

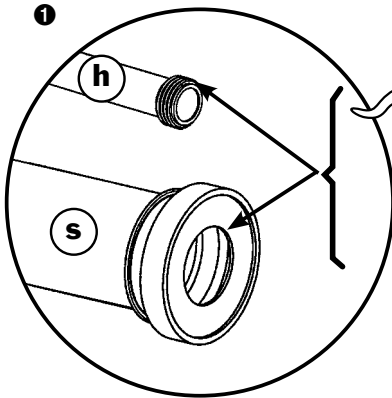
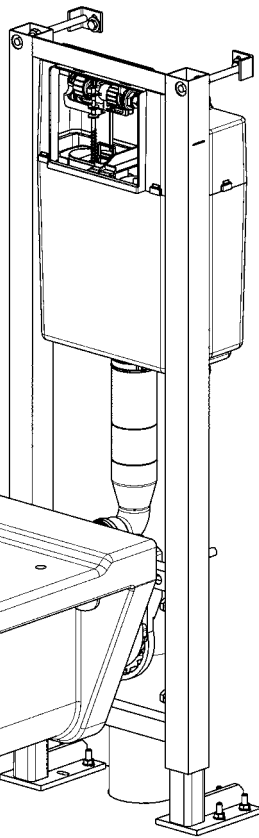

Silicone Grease

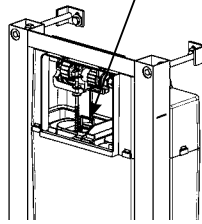
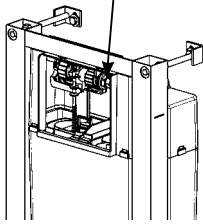
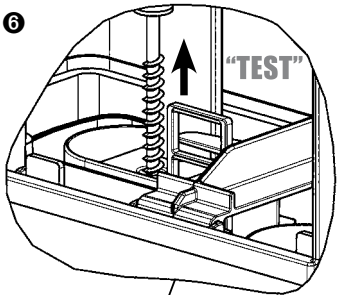
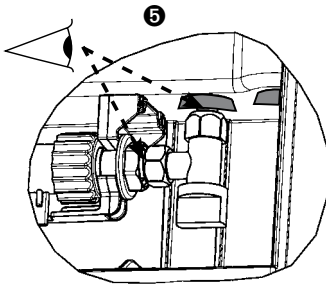
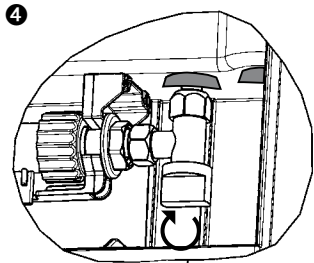
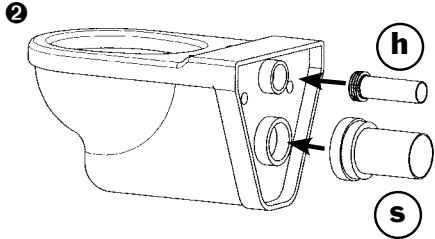

7

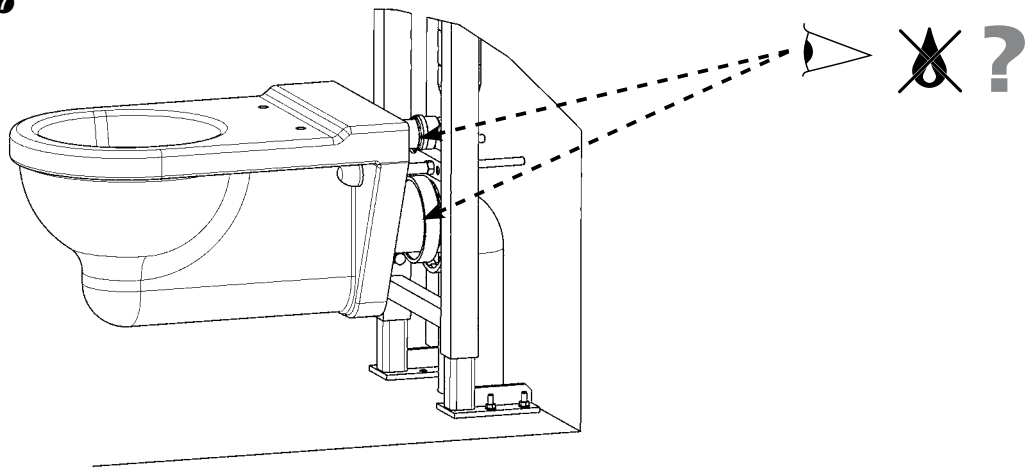

8

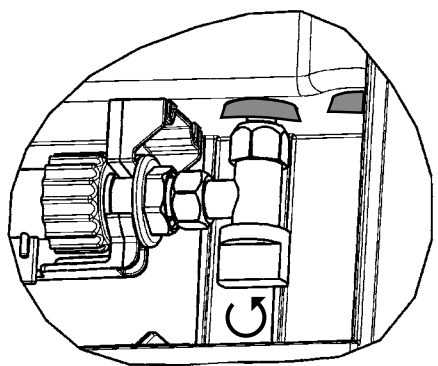

9



19

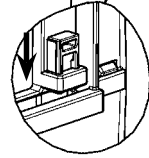
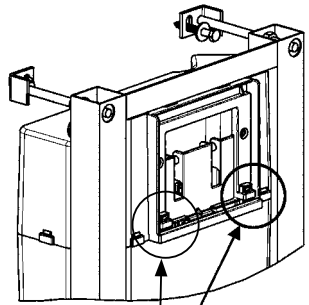
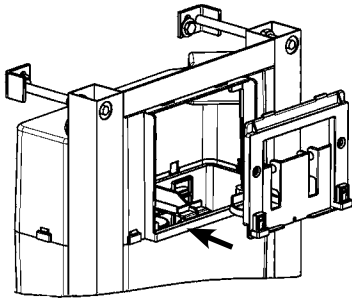

20

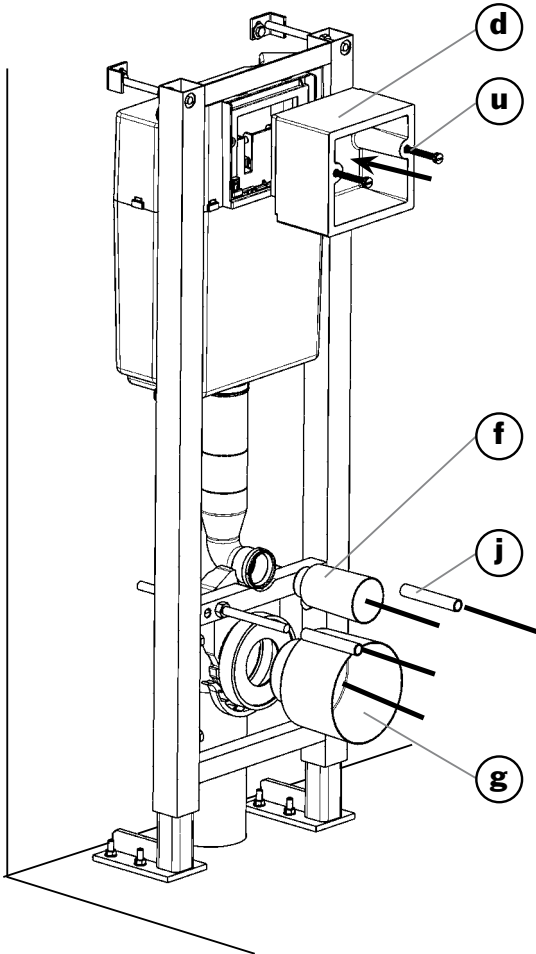

- CZ:** Na zadní straně balení naleznete měřítko pro vytvoení otvor. Kryt musí být upevněn do pevného podkladu.
- DAN:** Fremstil beklædningen. Anvend skabelonen bag på kartonen til udskæring af de forskellige huller. Beklædningen skal monteres direkte på stativets struktur.
- DEU:** Verkleidung einbauen. Für den Zuschnitt der verschiedenen Löcher nutzen sie die Schablone auf der Kartonrückseite. Die Verkleidung muss unbedingt fest mit dem Gestell verbunden werden.
- ESP:** Proceder a clocar la cubierta, para hacer los agujeros utilice el esquema que se encuentra en la cara detrás de la caja. La cubierta debe estar totalmente adosada a la estructura de la edificación.
- FRA:** Réaliser l'habillage, pour la découpe des différents trous utiliser le gabarit au dos du carton. L'habillage doit être impérativement solidaire à la structure du bâti.
- GB:** Make the cladding, for the preliminary punching out of the various holes use the measuring guage on the back of the packing. The covering must be fixed to the support structure.
- GRE:** Για την τοποθέτηση του καλύμματος, ανοίξτε τις διαφορετικές τρύπες, χρησιμοποιώντας το χάρτινο πατρόν που βρίσκεται μέσα στη συσκευασία. Το κάλυμμα πρέπει να στερεωθεί στο πλαίσιο στήριξης.
- H:** A lyukak előzetes kiütéséhez a mérőeszköz a csomagolás hátsó részében található. A tetőt rögzíteni kell, hogy a szerkezetet tartsa.
- LT:** Atlikti apdailą, skylių išpjovimui naudoti šablona ant kartono. Apdailos detalės turi atitikti karkaso struktūrą.
- NER:** De bekleding aanbrengen. Om de verschillende gaten uit te snijden, de mal op de achterzijde van het karton gebruiken. De bekleding moet verplicht één geheel vormen met de structuur van het onderstel.
- NOR:** Utfør beklædningen, for å skjære ut de forskjellige hullene anvendes malen bak på kartongen. Beklædningen skal nødvendigvis være solid festet til bygningsstrukturen.
- PL:** Przy wycinaniu różnych otworów (klapka z przyciskiem, kolana dopływowe i odpływowe i szpilki do mocowania muszli) należy skorzystać z szablonu znajdującego się w tylnej części opakowania.
- ROM:** Realizați îmbrăcămintea, pentru decuparea diferitelor găuri folosiți șablonul pe spatele cartonului. Îmbrăcămintea trebuie să fie neapărat solidară cu structura construcției.
- RUS:** Облицовка должна быть закреплена непосредственно к металлической раме инсталляционной системы
- SK:** Na zadnej strane sa nachádza merítko pre vytvorenie otvorov. Kryt musí byť upevnený do pevného podkladu.

22

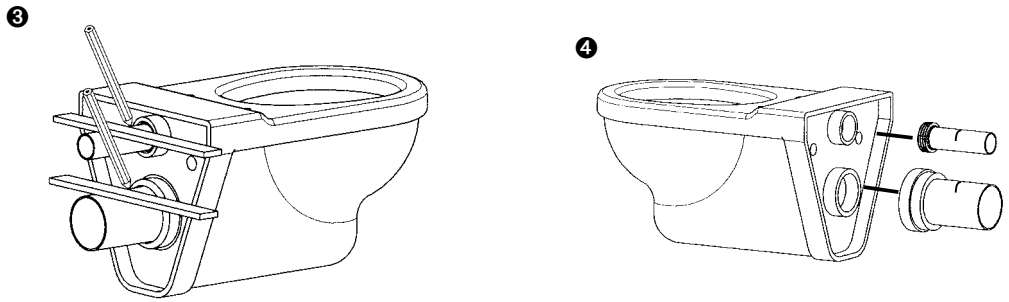
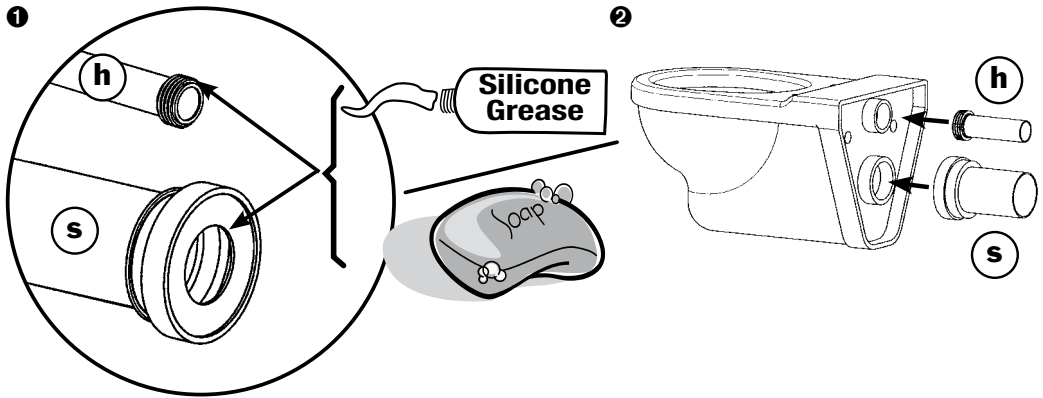

23

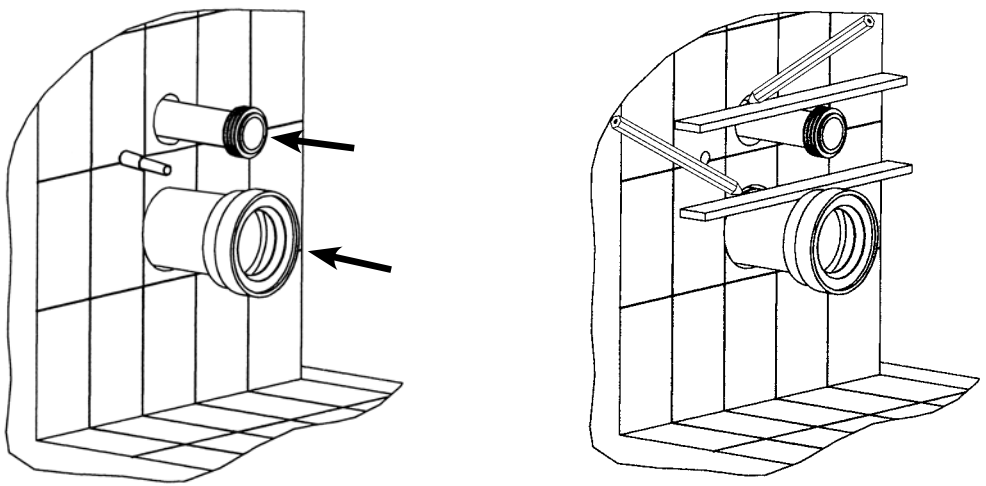

24

1

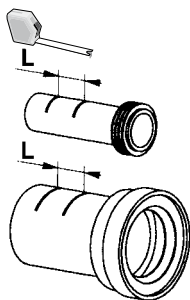

2

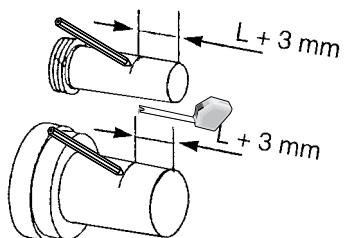

3

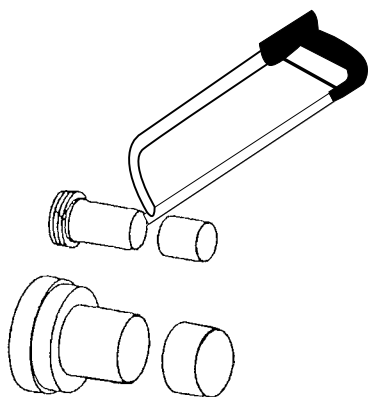

4

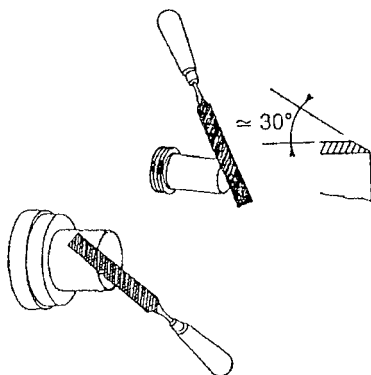

25

1 → 25-1

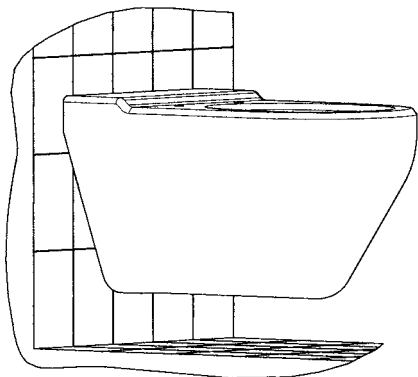

2 → 25-2

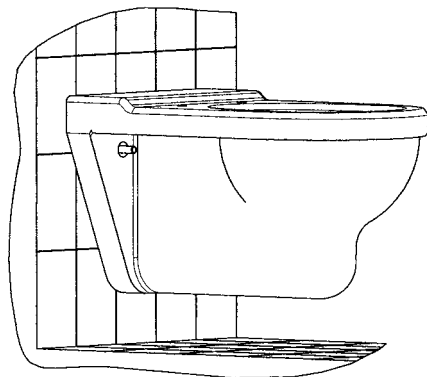

25-1

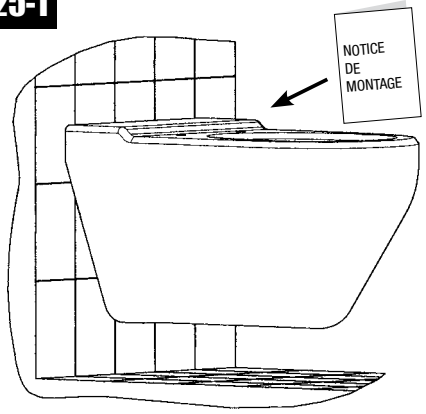

25-2

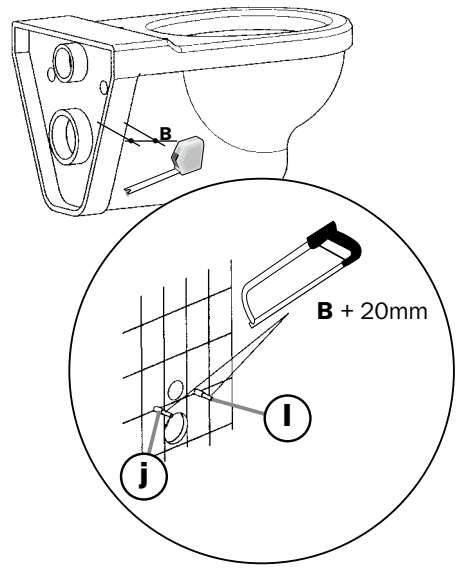

26

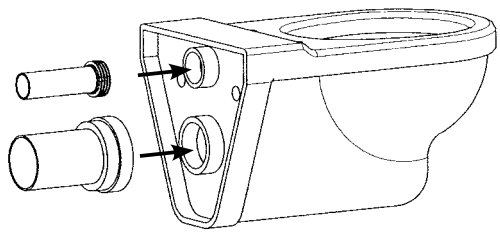

27

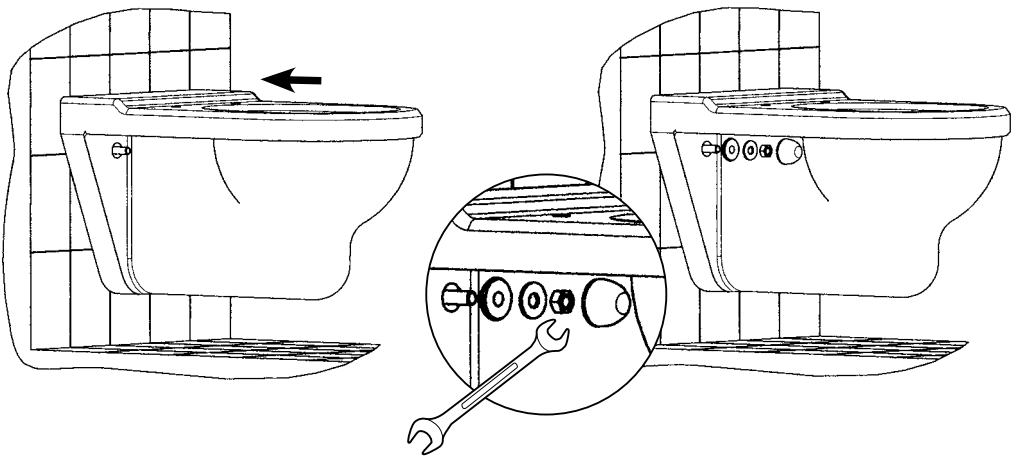

28

1

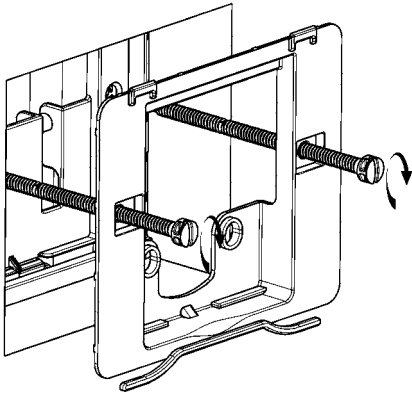

2

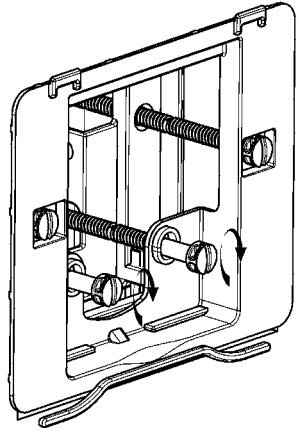

29

1

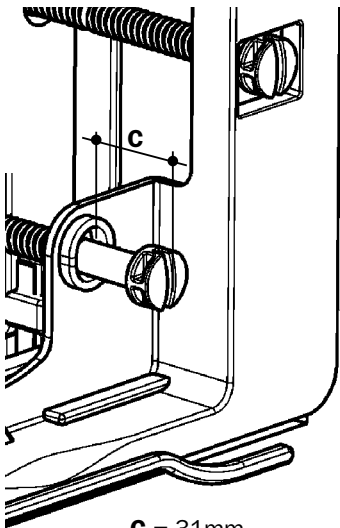

c = 31mm

2

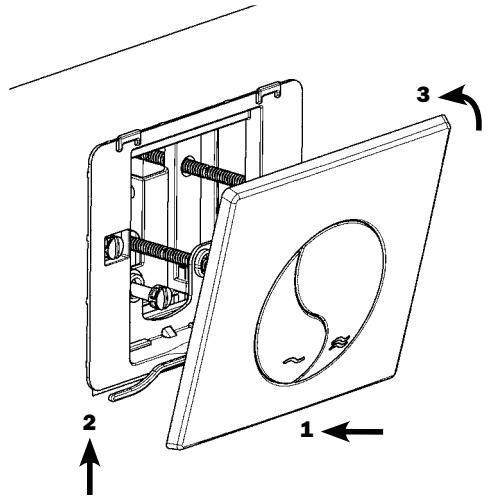

CZ: Údržbu
DAN: Vedligeholdelse
DEU: Wartung
ESP: Mantenimiento
FRA: Maintenance
GB: Maintenance
GRE: Συντήρηση
H: Útmutató
LT: Priežiūra.
NER: Onderhoud
NOR: Vedlikehold
PL: Konserwacja
ROM: Întreținere
RUS: Техническое обслуживание
SK: Údržbu

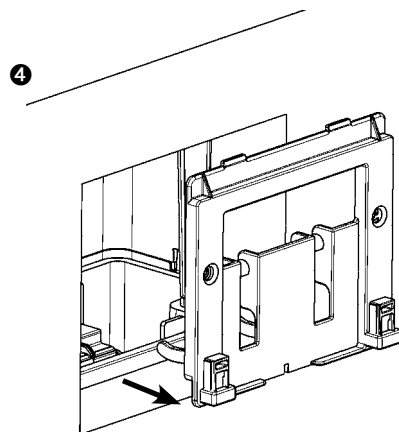
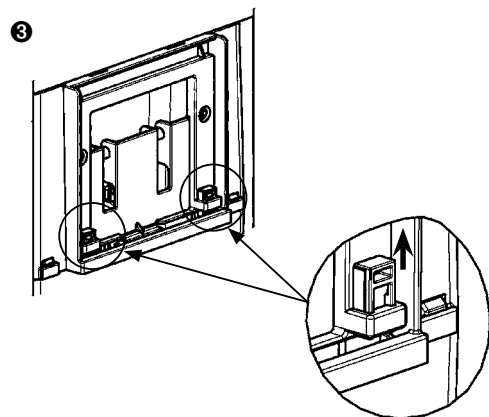
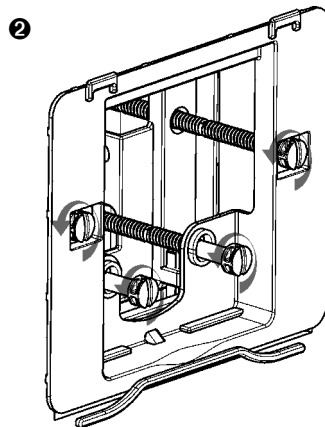
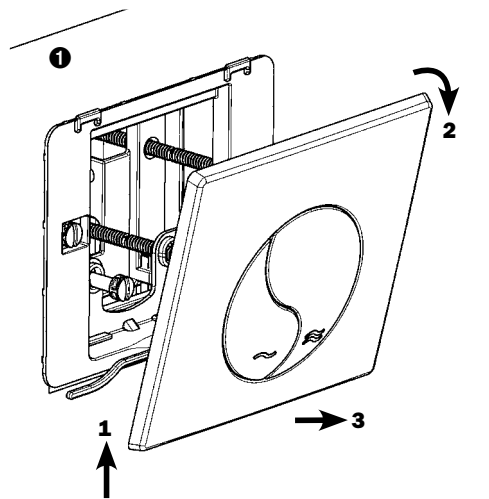

5

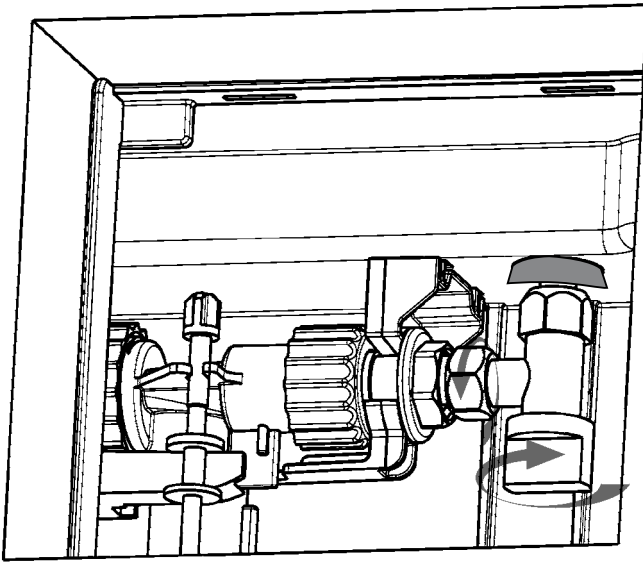

6

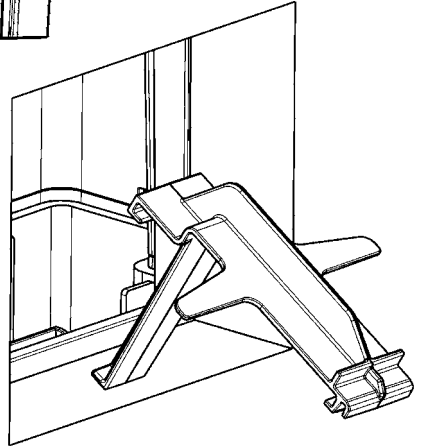

7

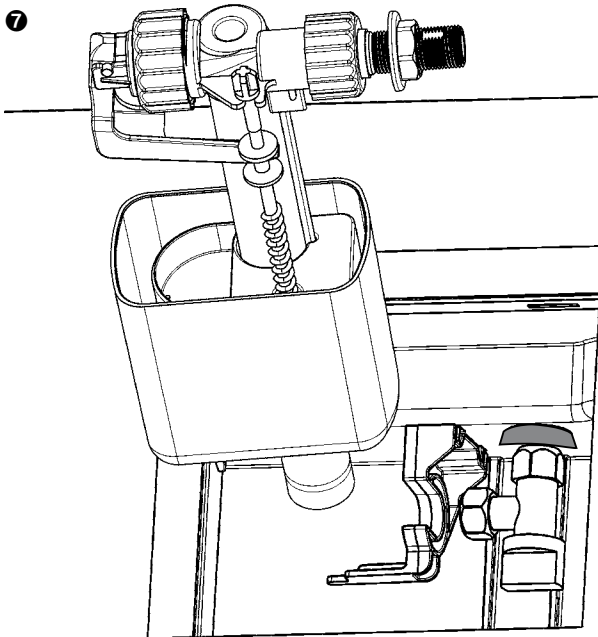

8

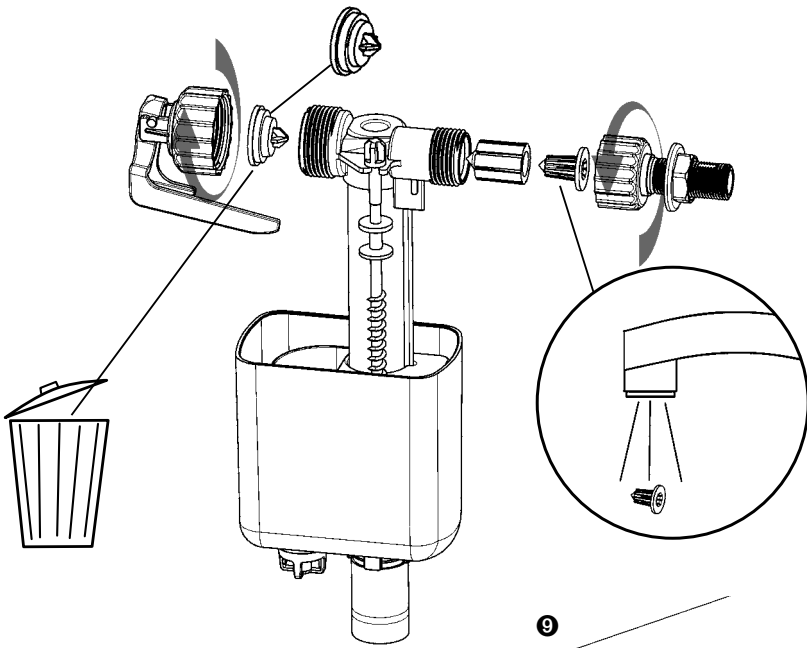

9

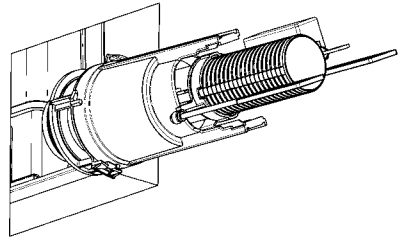

10

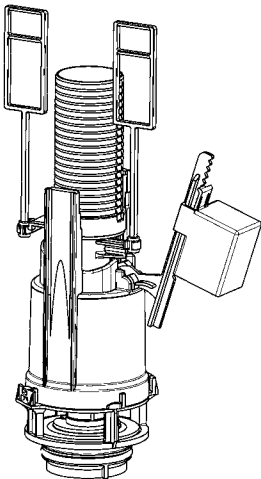

11

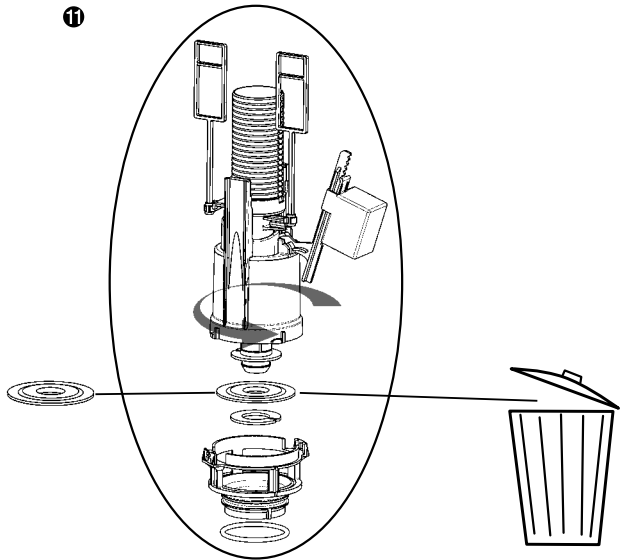



FRA: Hors pièces en caoutchouc.
CZ: Nevztahuje se na gumové části.
DAN: Gummidele ikke inkluderet.
DEU: Gilt nicht für Teile aus Gummi.
ESP: No incluye las partes de goma.
GRE: Δεν περιλαμβάνονται τα εξαρτήματα από καουτσούκ.
H: A gumi alkatrészekre nem vonatkozik.
LT: Netaikoma dalims iš kaučiuko.
NER: Rubberen onderdelen niet inbegrepen.
NOR: Gummideler ikke inkludert.
PL: Gwarancja nie dotyczy elementów gumowych.
ROM: Nu include piesele din cauciuc.
RUS: Гарантия не распространяется на резиновые части.
SK: Nevztahuje sa na gumené časti.

- La société se réserve le droit de modifier le produit sans préavis tout en assurant la permanence de ses fonctions.
- The company reserves the right to modify the product without notice while ensuring the permanence of its functions.